

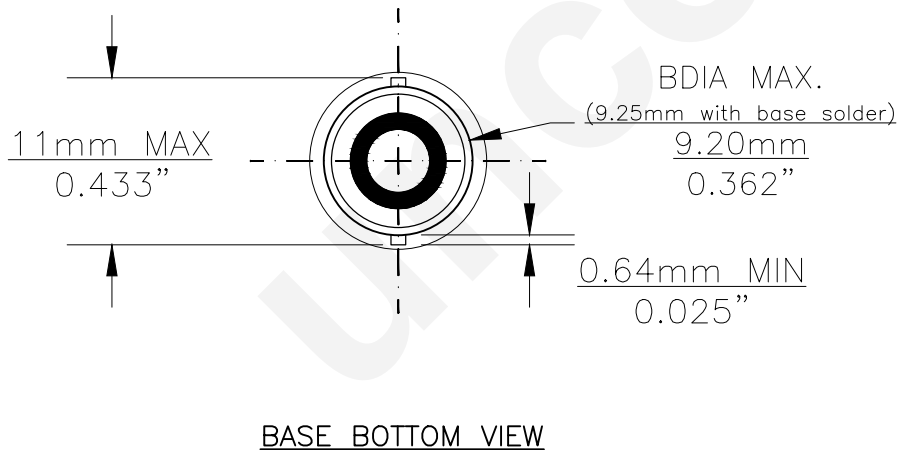

PART NO.	BASE TYPE	DESIGN VOLTS	DESIGN AMPS	MSCD	FILAMENT TYPE	AVERAGE LIFE HOURS	REVISIONS			
							REV #	DESCRIPTION	DATE	APPROVED
219	MINIATURE BAYONET (BA9s)	6.3V	0.25±15%	0.5±30%	C-2V	5000	1	ISSUED	03/10/2016	R.M.

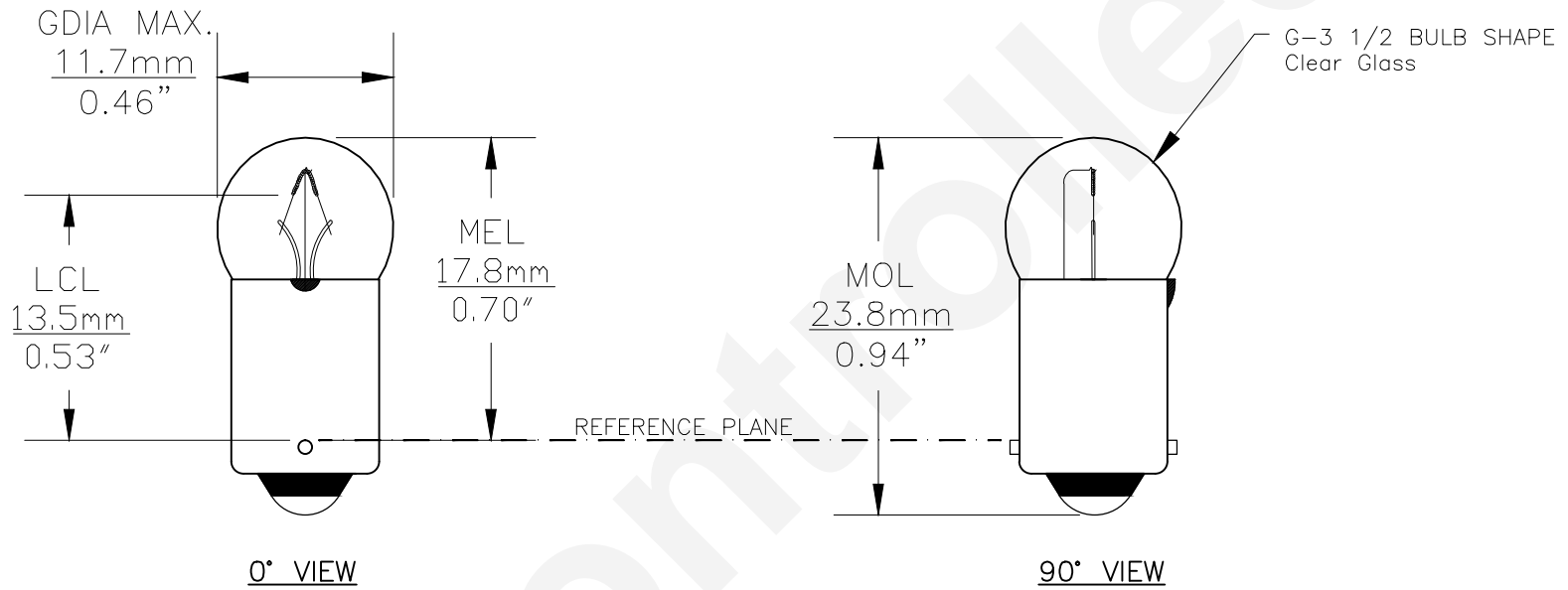

Note: Made according to SAE specifications

UNLESS OTHERWISE SPECIFIED: DIMENSIONS ARE IN INCHES TOLERANCES		CEC INDUSTRIES LTD			
DECIMALS	ANGULAR	599 BOND STREET		LINCOLNSHIRE, IL 60069	
.XX ± .05	± 0.5°				
.XXX ± .010					
FRACTIONAL	± 1/64				
DRAWN ROSE MEDINA	DATE 03/10/2016	TITLE LIGHT BULB NO. 219			
CHECKED	SIZE A	FSCM NO.	DWG NO. 219	REV 1	
DESIGN	SCALE	PLOT SCALE	SHEET 1 OF 1		
MATERIAL	FILE 219.pdf	DRAWING NOT TO SCALE			